

© 2013 Essentra Components. All rights reserved.  
 Registered in England, Company No. 547495.  
 Registered Office: Essentra plc  
 Langford Locks, Kidlington, Oxford, OX5 1HX

Condition of Sale can be found on our website: [essentra.com](http://essentra.com).

Essentra Components does not warrant that the files will be error free and may create new versions ("Upgrades") at any time, which may correct such errors. Essentra Components has no obligation to notify you of such upgrades. Any upgraded file will be published to the website, when it becomes available.

You are not permitted to load any of the files on to a network server for the purposes of distribution to one or more other computer(s) on that network or to effect such distribution. Essentra Components shall not be liable for any loss or damage whatsoever or however caused, arising directly or indirectly from the use of the files.

**UNCONTROLLED COPY**

STATUS **APPROVED DRAWING**

UNLESS OTHERWISE STATED

ALL DIMENSIONS IN MM

DO NOT SCALE

LINEAR TOLERANCE			
SIZE	(0)	(0.0)	(0.00)
0-10	±0.5	±0.15	±0.10
>10-30	±0.5	±0.20	±0.15
>30-50	±0.5	±0.30	±0.20
>50-100	±0.8	±0.50	±0.25
>100-200	±1.5	±0.80	±0.40
>200-300	±2.0	±1.20	±0.80
>300-500	±3.0	±2.00	±1.00
>500	±5.0	±3.00	±1.50

THIRD ANGLE PROJECTION	
ANGULAR TOLERANCE ±0.5 DEGREES	
UNSPECIFIED RADII 0.25mm	
DRAFT ANGLE 0.5 DEGREES	
DIMENSIONS IN PARENTHESIS ( ) ARE FOR REFERENCE ONLY	

ITEM CODE	20472535	CREATE DATE	20/03/2025
LEGACY CODE	12SWS2527B	MATERIAL	PA66
		COLOUR	BLACK
		FINISH	-

TITLE:  
 SHOULDER WASHER  
 -

DWG. No.	20472535	SCALE	3:1	ISSUE	1
				SHEET	1 of 2

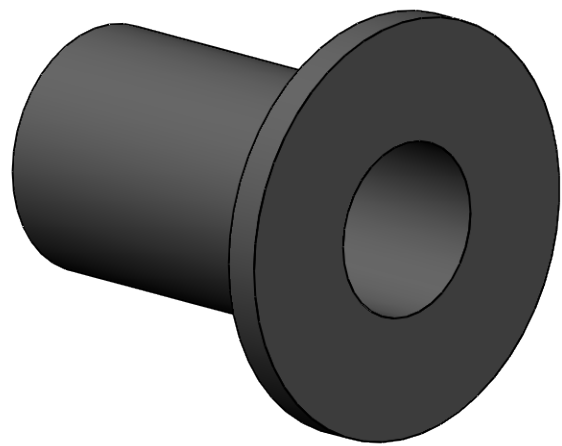
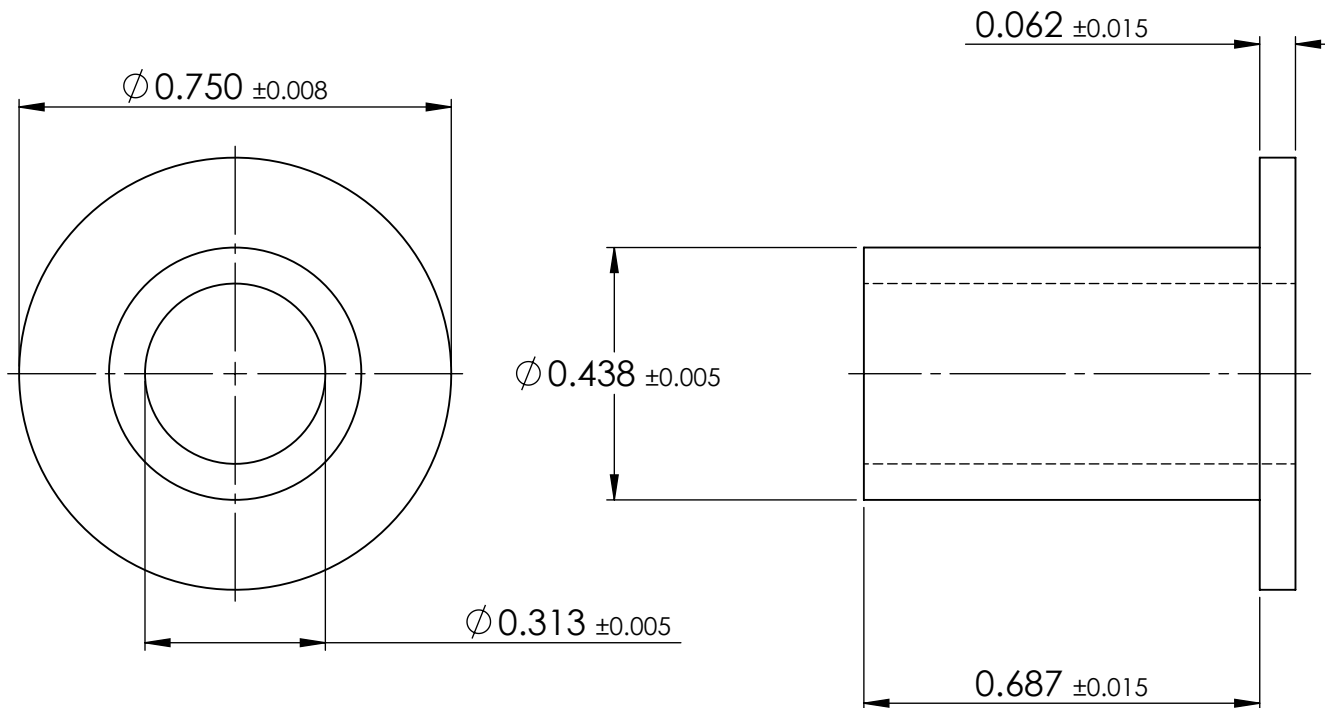

© 2013 Essentra Components. All rights reserved.  
 Registered in England, Company No. 547495.  
 Registered Office: Essentra plc  
 Langford Locks, Kidlington, Oxford, OX5 1HX

Condition of Sale can be found on our website: [essentra.com](http://essentra.com).

Essentra Components does not warrant that the files will be error free and may create new versions ("Upgrades") at any time, which may correct such errors. Essentra Components has no obligation to notify you of such upgrades. Any upgraded file will be published to the website, when it becomes available.

You are not permitted to load any of the files on to a network server for the purposes of distribution to one or more other computer(s) on that network or to effect such distribution. Essentra Components shall not be liable for any loss or damage whatsoever or however caused, arising directly or indirectly from the use of the files.

**UNCONTROLLED COPY**

STATUS **APPROVED DRAWING**

UNLESS OTHERWISE STATED

ALL DIMENSIONS IN inches			DO NOT SCALE
LINEAR TOLERANCE			THIRD ANGLE PROJECTION
SIZE	(0.00)	(0.000)	(0.0000)
0 - 0.394	±0.020	±0.006	±0.004
>0.394 - 1.181	±0.020	±0.008	±0.006
>1.181 - 1.969	±0.020	±0.012	±0.008
>1.969 - 3.937	±0.031	±0.020	±0.010
>3.937 - 7.874	±0.059	±0.031	±0.016
>7.874 - 11.811	±0.079	±0.047	±0.031
>11.811 - 19.685	±0.118	±0.079	±0.039
>19.685	±0.197	±0.118	±0.059

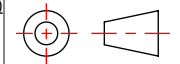

ANGULAR TOLERANCE  
 ±0.5 DEGREES  
 UNSPECIFIED RADIUS 0.25mm  
 DRAFT ANGLE 0.5 DEGREES  
 DIMENSIONS IN PARENTHESES  
 ( ) ARE FOR REFERENCE ONLY

ITEM CODE	20472535	20/03/2025	CREATE DATE
LEGACY CODE	12SWS2527B	PA66	MATERIAL
		BLACK	COLOUR
		-	FINISH

TITLE:  
 SHOULDER WASHER  
 -

DWG. No.	20472535	SCALE	ISSUE
		3:1	1
		SHEET	2 of 2